

Front Bumper Fascia Replacement

Removal Procedure

Caution: Refer to [Safety Glasses Caution](#) in the Preface section.

Caution: Refer to [Vehicle Lifting Caution](#) in the Preface section.

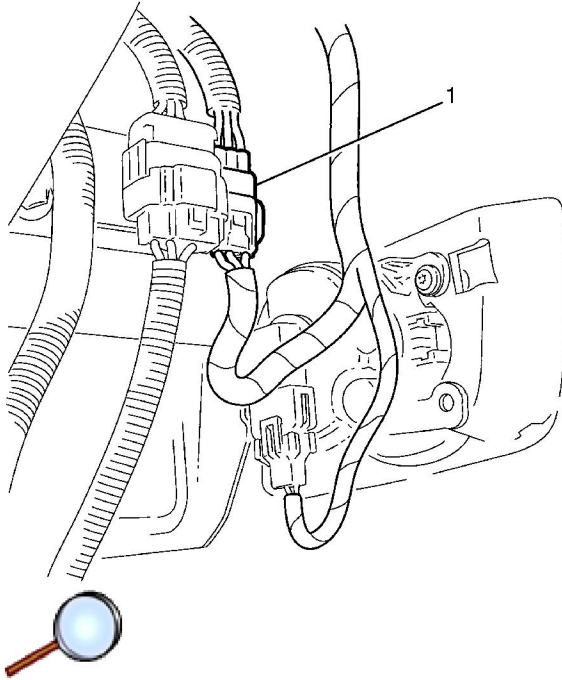

1. Raise and support the vehicle. Refer to [Lifting and Jacking the Vehicle](#) .
2. Remove the front wheelhouse liner. Refer to [Front Wheelhouse Liner Replacement](#) .

Repeat for opposite side.

3. Disconnect the front end module to front bumper fascia wiring harness (1).

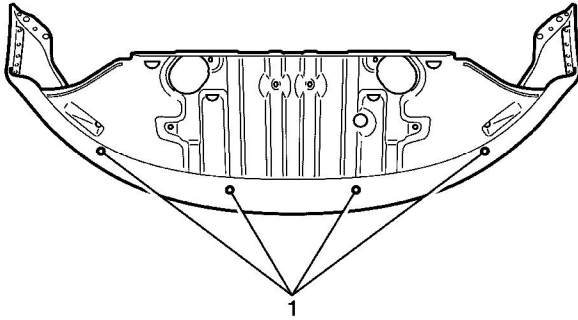

4. Remove the front air deflector retaining screws (1).

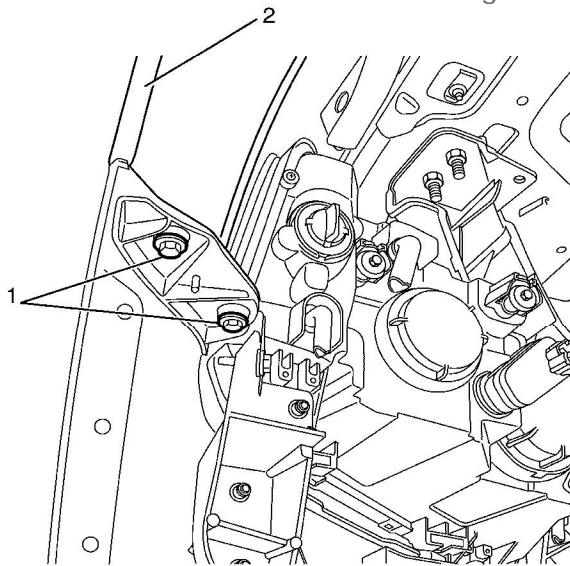

5. Loosen the front bumper fascia to fender retaining bolts (1).
6. Using suitable force, push the front bumper fascia to fender retaining bolts (1) upwards to disengage from the fender (2).

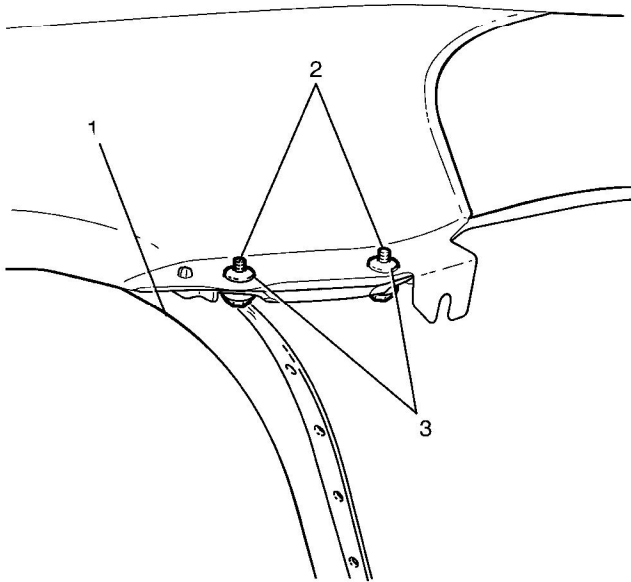

7. Disengage the front bumper fascia (1) from the key slots (2) in the front fender attachment points (3).
8. Lower the vehicle.

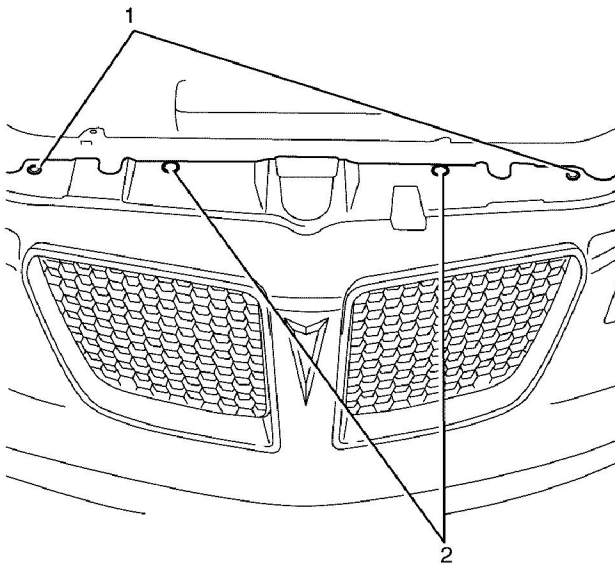

9. Remove the front bumper fascia to front fascia upper fasteners (1).
10. Remove the front bumper fascia (3) to front end module push-in retainers (2).

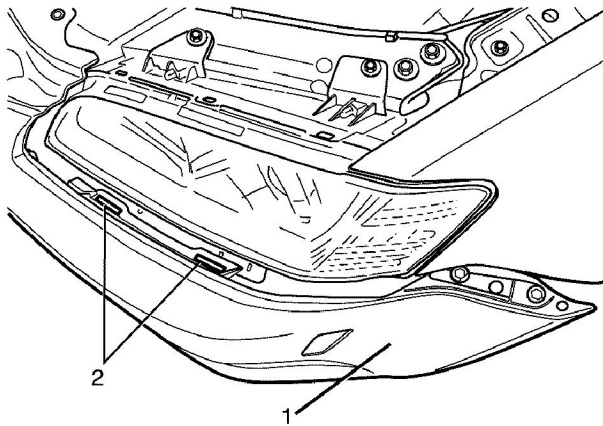

11. Disengage the front bumper fascia (1) from the front bumper fascia support bracket retaining tabs (2).
12. Remove the front bumper fascia (1) from the vehicle.

Disassembly Procedure

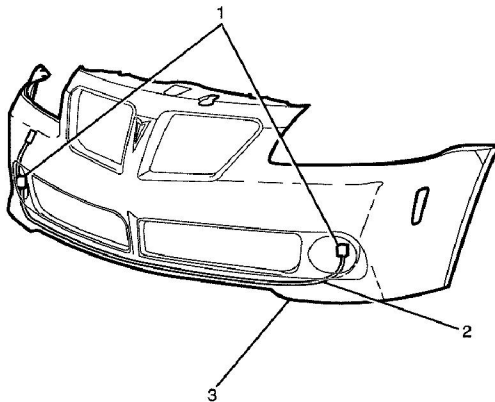

1. Remove the front bumper fascia radiator grille. Refer to [Radiator Grille Replacement](#) .
2. Remove the front bumper fascia insert. Refer to [Front Bumper Lower Fascia Grille Replacement](#) .

Repeat for opposite side.

3. Disconnect the front fog lamp electrical connectors (1), then disengage and remove the electrical wiring harness (2) from the front bumper fascia (3), disengaging the guide clips (4).

Repeat for opposite side.

4. Remove the front bumper fascia reflector. Refer to [Front Bumper Fascia Reflector Replacement](#) .

Repeat for opposite side.

5. Remove the front fog lamp. Refer to [Front Fog Lamp Replacement](#) .

Repeat for opposite side.

Assembly Procedure

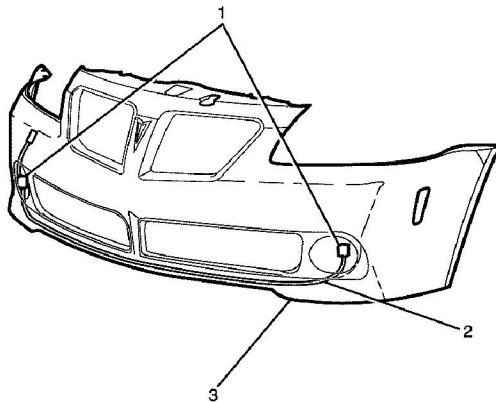

1. Install the electrical wiring harness (2) onto the front bumper fascia (3), engaging the guide clips (4).
2. Connect the fog lamp electrical connectors (1).
3. Install the front fog lamp. Refer to [Front Fog Lamp Replacement](#) .

Repeat for opposite side.

4. Install the front bumper fascia reflector. Refer to [Front Bumper Fascia Reflector Replacement](#) .

Repeat for opposite side.

5. Connect the electrical connectors (2) to the side markers.
6. Connect the front fog lamp electrical connectors (1) to the front fog lamps.

7. Install the front bumper fascia insert. Refer to [Front Bumper Lower Fascia Grille Replacement](#) .

Repeat for opposite side.

8. Install the front bumper fascia radiator grille. Refer to [Radiator Grille Replacement](#) .

Repeat for opposite side.

Installation Procedure

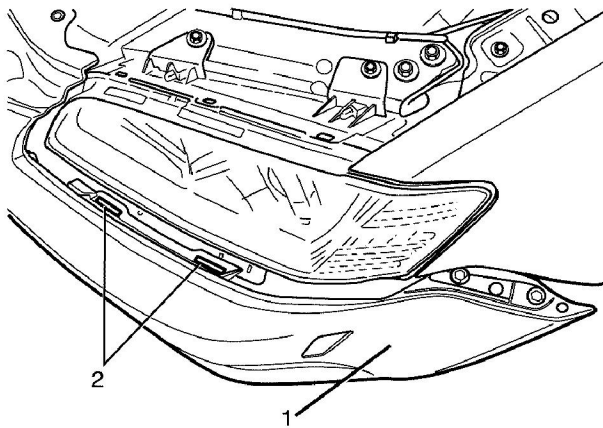

1. With the aid of an assistant, position the front bumper fascia to the vehicle.
2. Applying suitable pressure, engage the front bumper fascia (1) onto the front bumper fascia support bracket retaining tabs (2).
3. Raise and support the vehicle. Refer to [Lifting and Jacking the Vehicle](#) .

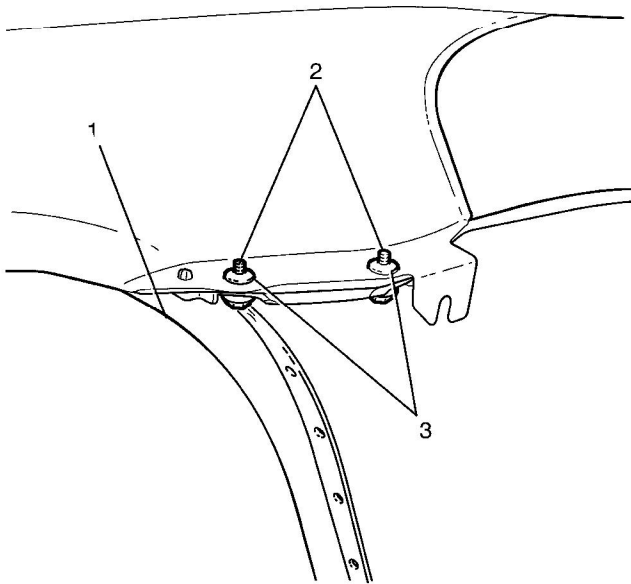

4. Engage the front bumper fascia (1) onto the key slots (2) in the front fender attachment points (3).

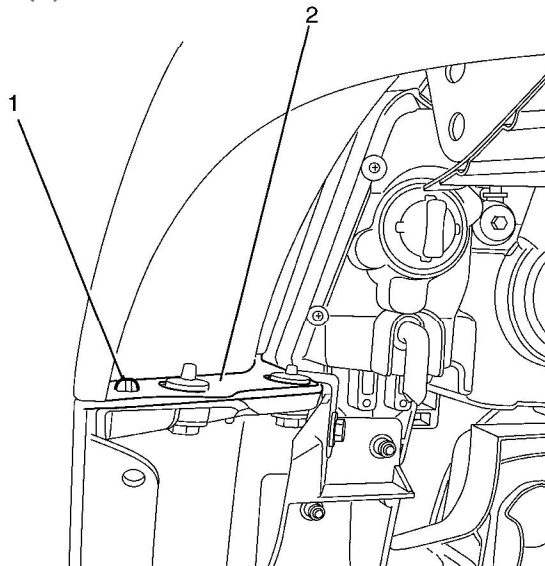

5. Align the locating pin (1) to the locating hole in the fender (2).
6. Push the front bumper fascia rearward in order to adjust.

Notice: Refer to [Component Fastener Tightening Notice](#) in the Preface section.

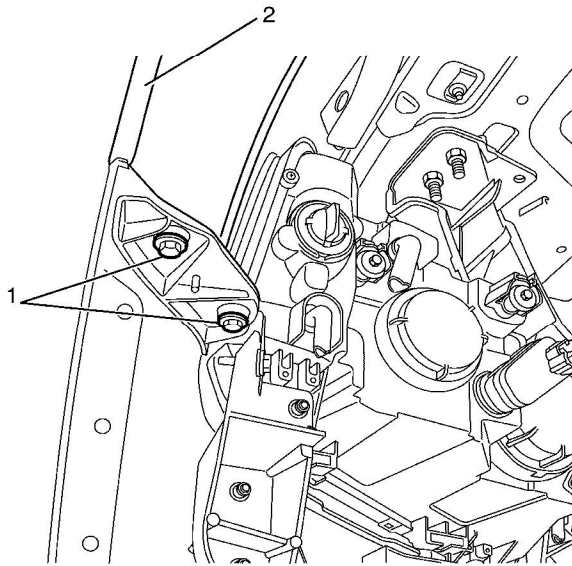

7. Engage the front bumper fascia to fender retaining bolts (1) into the fender (2).
8. Tighten the front fascia upper fasteners (1).

Tighten

Tighten the bolts to 10 N·m (89 lb in).

Notice: Refer to [Component Fastener Tightening Notice](#) in the Preface section.

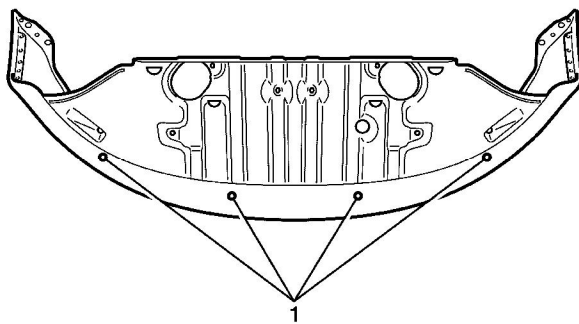

9. Install the front bumper fascia to front air deflector retaining screws (1).

Tighten

Tighten the screws to 3 N·m (27 lb in).

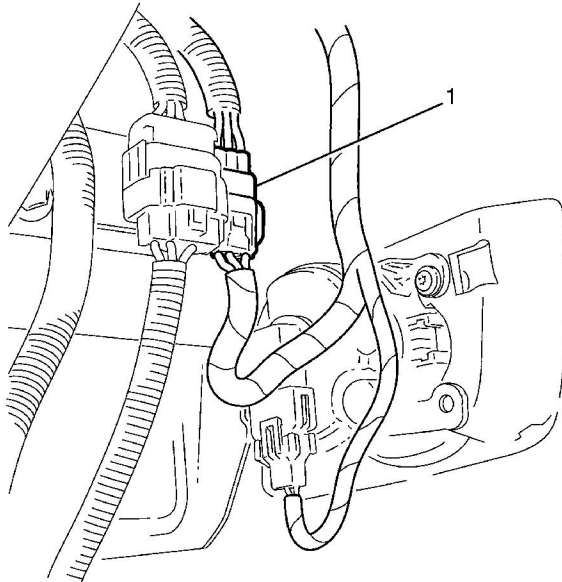

10. Connect the front end module to front bumper fascia wiring harness (1).

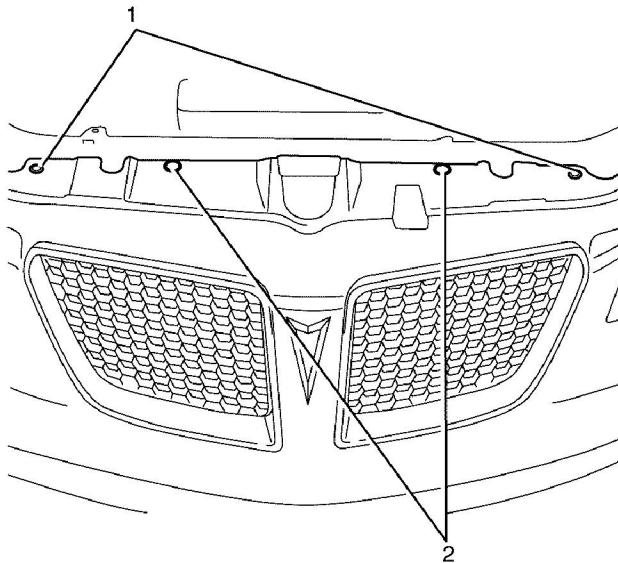

11. Install the front bumper fascia to front end module push-in retainers (2).

Notice: Refer to [Component Fastener Tightening Notice](#) in the Preface section.

12. Install the front bumper fascia (3) to front end module retaining bolts (1).

Tighten

Tighten the screws to 4.5 N·m (39 lb in).

13. Install the front wheelhouse liner. Refer to [Front Wheelhouse Replacement](#) .

Repeat for opposite side.

14. Lower the vehicle.